



**InGranite Recon Ltd.**

Cast Stone | Modern Material | Classic Style

# Cast Stone Street Furniture Seats - Planters - Bollards

**Contact**

Phone:

Email:

Web:

**UK**

0808 2349 118

[info@ingranite.co.uk](mailto:info@ingranite.co.uk)

[www.ingranite.co.uk](http://www.ingranite.co.uk)

**Rep. Irl.**

057 9331 462

[info@ingranite.ie](mailto:info@ingranite.ie)

[www.ingranite.ie](http://www.ingranite.ie)







## **InGranite Recon Ltd.**

Cast Stone | Modern Material | Classic Style

# Cast Stone Street Furniture Seats - Planters - Bollards

InGranite Recon manufactures a range of elegant cast stone street furniture units. All of our seats/benches, street planters and bollards are manufactured in beautiful and durable reconstituted granite.

Please contact us if you require a bespoke or modified design for your project.

#### Contact

Phone:  
Email:  
Web:

#### UK

0808 2349 118  
info@ingranite.co.uk  
www.ingranite.co.uk

#### Rep Irl.

057 9331 462  
info@ingranite.ie  
www.ingranite.ie



# InGranite Recon Ltd.

Reconstituted Stone | Modern Material | Classic Style

UK info@ingranite.co.uk

RoI info@ingranite.ie

www.ingranite.co.uk

www.ingranite.ie

0808 2349118

057 9331462

## Technical specification sheet

Title: Bench seat 216

Date: 07/04/2017

Ref: BS 216

Scale: 1:16

Drawn by: InGranite

Approximate weight: 1135kgs

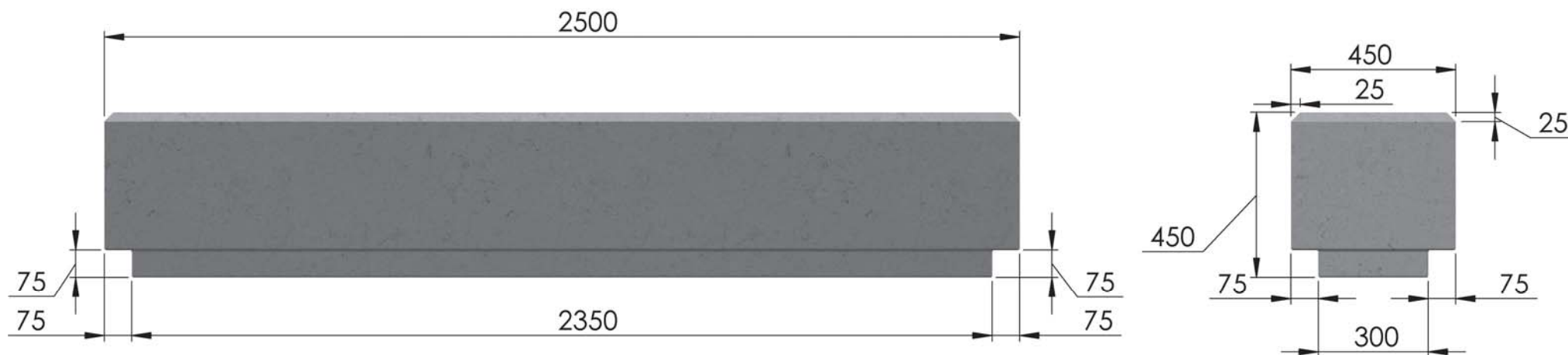

All dimensions are in millimetres. For non listed sizes please contact InGranite Recon LTD.

All vertical faces typically have a 4mm taper per 100mm of height.

The information contained in this drawing was correct at the time of going to print. Profiles, sizes and weights are given as indication only.



# InGranite Recon Ltd.

Reconstituted Stone | Modern Material | Classic Style

UK info@ingranite.co.uk

www.ingranite.co.uk

0808 2349118

RoI info@ingranite.ie

www.ingranite.ie

057 9331462

## Technical specification sheet

Title: Burns seat	
Date: 07/04/2017	Ref: BS 2000
Scale: 1:16	Drawn by: InGranite
Approximate weight: 870kgs	

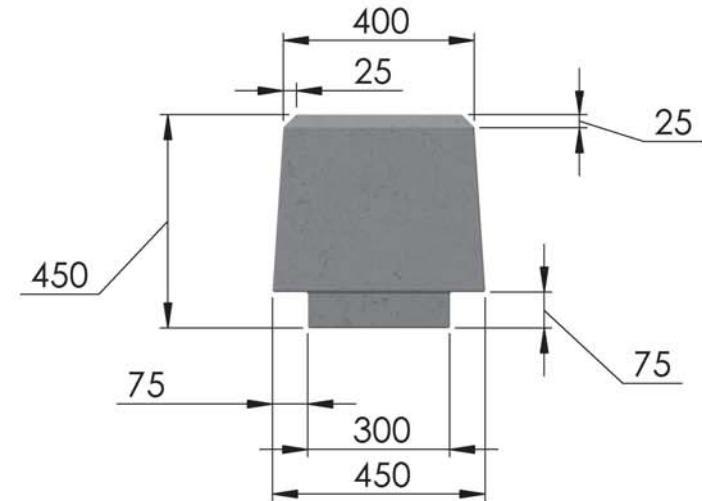
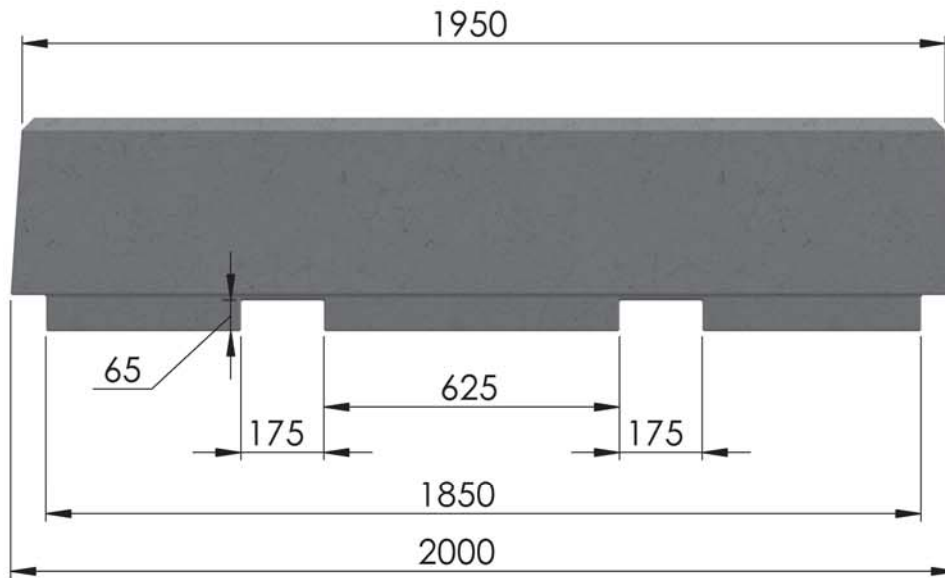

All dimensions are in millimetres. For non listed sizes please contact InGranite Recon LTD.

All vertical faces typically have a 4mm taper per 100mm of height.

The information contained in this drawing was correct at the time of going to print. Profiles, sizes and weights are given as indication only.



# InGranite Recon Ltd.

Reconstituted Stone | Modern Material | Classic Style

UK info@ingranite.co.uk

www.ingranite.co.uk

0808 2349118

RoI info@ingranite.ie

www.ingranite.ie

057 9331462

## Technical specification sheet

Title: Circular seat

Date: 07/04/2017

Ref: CS 2500

Scale: 1:20

Drawn by: InGranite

Approximate weight: 468kgs per section

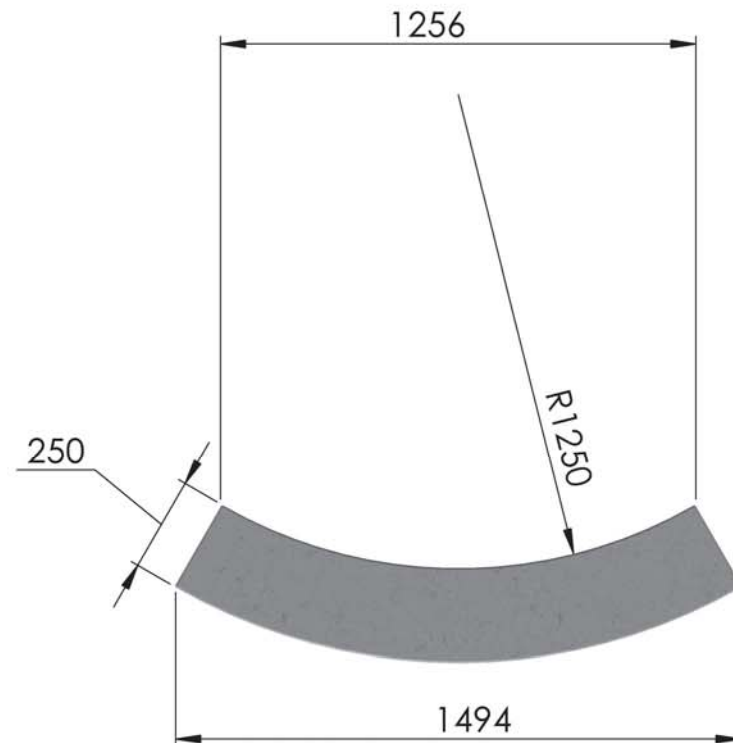

All dimensions are in millimetres. For non listed sizes please contact InGranite Recon LTD.

All vertical faces typically have a 4mm taper per 100mm of height.

The information contained in this drawing was correct at the time of going to print. Profiles, sizes and weights are given as indication only.





# InGranite Recon Ltd.

Reconstituted Stone | Modern Material | Classic Style

UK info@ingranite.co.uk

www.ingranite.co.uk

0808 2349118

RoI info@ingranite.ie

www.ingranite.ie

057 9331462

## Technical specification sheet

Title:	London seat 1		
Date:	27/02/2017	Ref:	LS1
Scale:	1:20	Drawn by:	InGranite
Approximate weight:	1323.5kgs		

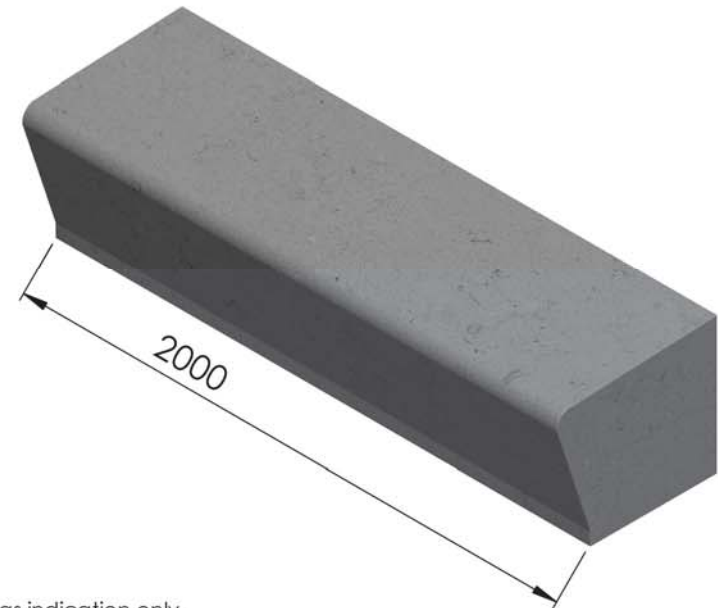
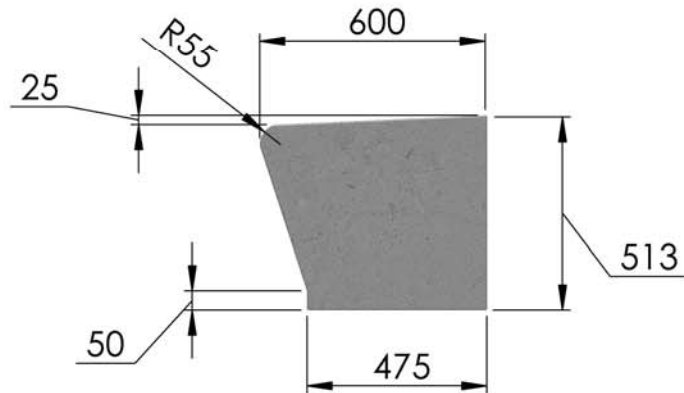

All dimensions are in millimetres. For non listed sizes please contact InGranite Recon LTD.

All vertical faces typically have a 4mm taper per 100mm of height.

The information contained in this drawing was correct at the time of going to print. Profiles, sizes and weights are given as indication only.



# InGranite Recon Ltd.

Reconstituted Stone | Modern Material | Classic Style

UK info@ingranite.co.uk

RoI info@ingranite.ie

www.ingranite.co.uk

www.ingranite.ie

0808 2349118

057 9331462

## Technical specification sheet

Title: London seat 2

Date: 28/02/2017

Ref: LS2

Scale: 1:20

Drawn by: InGranite

Approximate weight:

1286kgs

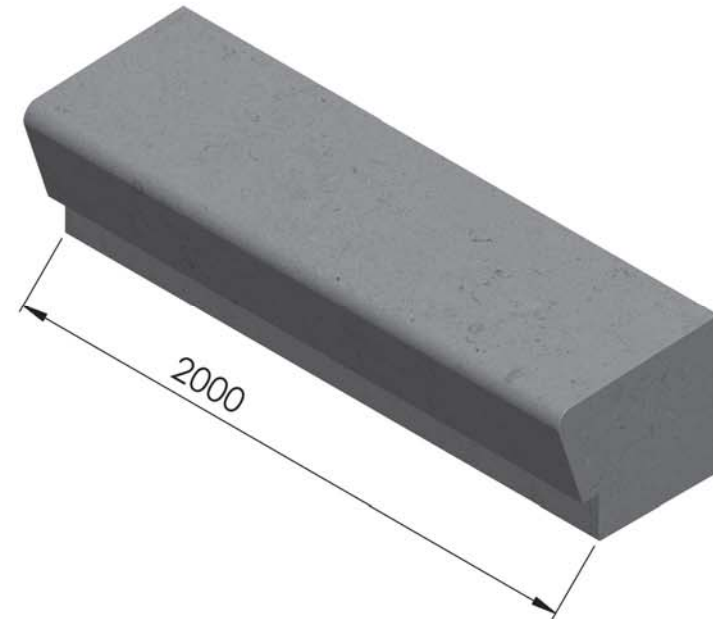
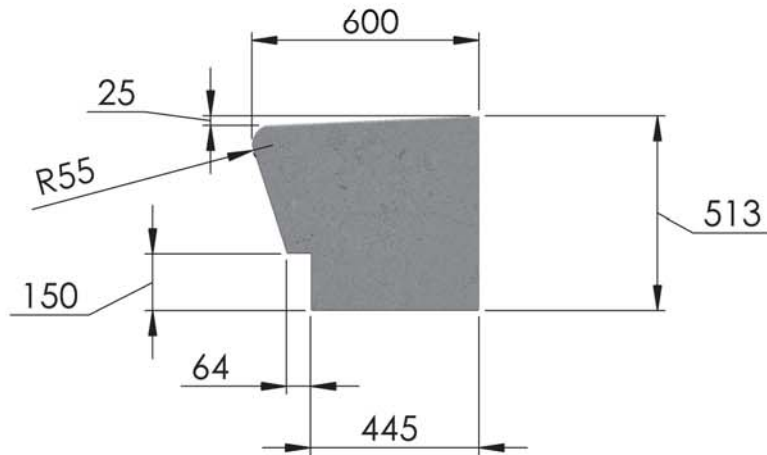

All dimensions are in millimetres. For non listed sizes please contact InGranite Recon LTD.

All vertical faces typically have a 4mm taper per 100mm of height.

The information contained in this drawing was correct at the time of going to print. Profiles, sizes and weights are given as indication only.





# InGranite Recon Ltd.

Reconstituted Stone | Modern Material | Classic Style

UK info@ingranite.co.uk

www.ingranite.co.uk

0808 2349118

RoI info@ingranite.ie

www.ingranite.ie

057 9331462

## Technical specification sheet

Title: London bench seat 3

Date: 03/03/2017

Ref: LS3

Scale: 1:20

Drawn by: InGranite

Approximate weight: 1300kgs

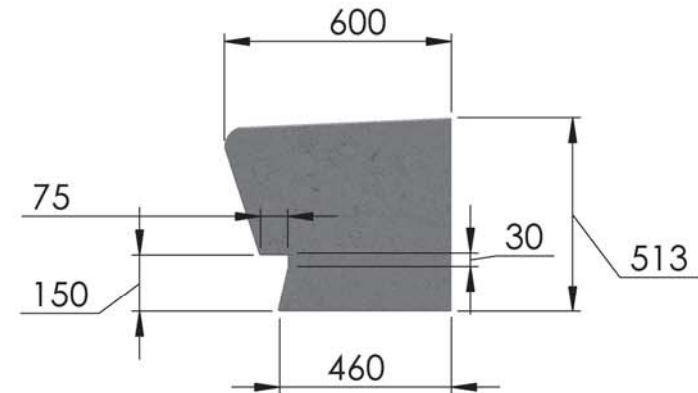
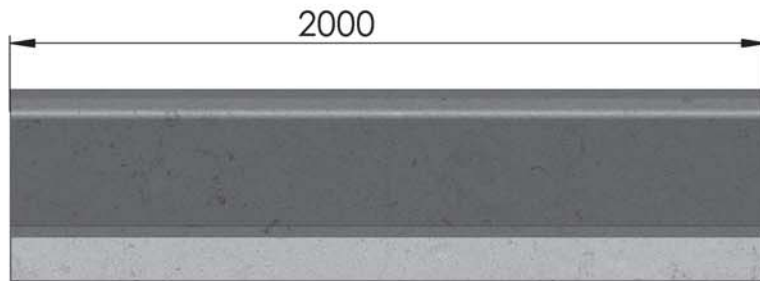

All dimensions are in millimetres. For non listed sizes please contact InGranite Recon LTD.

All vertical faces typically have a 4mm taper per 100mm of height.

The information contained in this drawing was correct at the time of going to print. Profiles, sizes and weights are given as indication only.



# InGranite Recon Ltd.

Reconstituted Stone | Modern Material | Classic Style

UK info@ingranite.co.uk

www.ingranite.co.uk

0808 2349118

RoI info@ingranite.ie

www.ingranite.ie

057 9331462

## Technical specification sheet

Title: London bench seat 4

Date: 03/03/2017

Ref: LS4

Scale: 1:20

Drawn by: InGranite

Approximate weight: 1300kgs

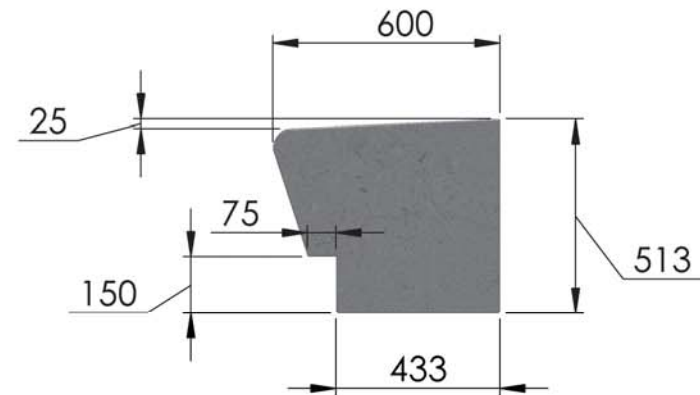
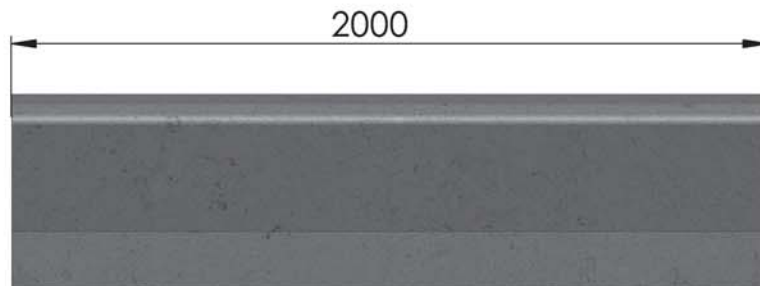

All dimensions are in millimetres. For non listed sizes please contact InGranite Recon LTD.

All vertical faces typically have a 4mm taper per 100mm of height.

The information contained in this drawing was correct at the time of going to print. Profiles, sizes and weights are given as indication only.



# InGranite Recon Ltd.

Reconstituted Stone | Modern Material | Classic Style

UK info@ingranite.co.uk

www.ingranite.co.uk

0808 2349118

RoI info@ingranite.ie

www.ingranite.ie

057 9331462

## Technical specification sheet

Title: Pierse seat

Date: 07/04/2017

Ref: PS 2010

Scale: 1:16

Drawn by: InGranite

Approximate weight: 1371kgs

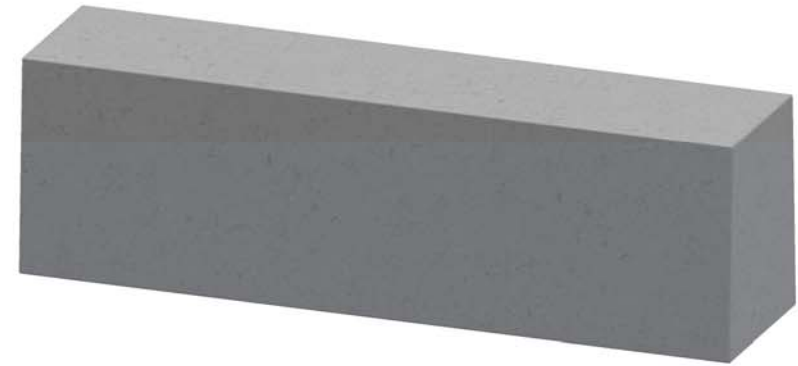

All dimensions are in millimetres. For non listed sizes please contact InGranite Recon LTD.

All vertical faces typically have a 4mm taper per 100mm of height.

The information contained in this drawing was correct at the time of going to print. Profiles, sizes and weights are given as indication only.



# InGranite Recon Ltd.

Reconstituted Stone | Modern Material | Classic Style

UK info@ingranite.co.uk

www.ingranite.co.uk

0808 2349118

RoI info@ingranite.ie

www.ingranite.ie

057 9331462

## Technical specification sheet

Title: Radius bench seat

Date: 01/03/2017

Ref: RS 600

Scale: 1:20

Drawn by: InGranite

Approximate weight:

1147kgs

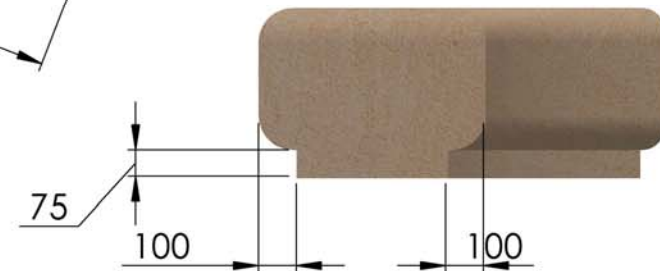
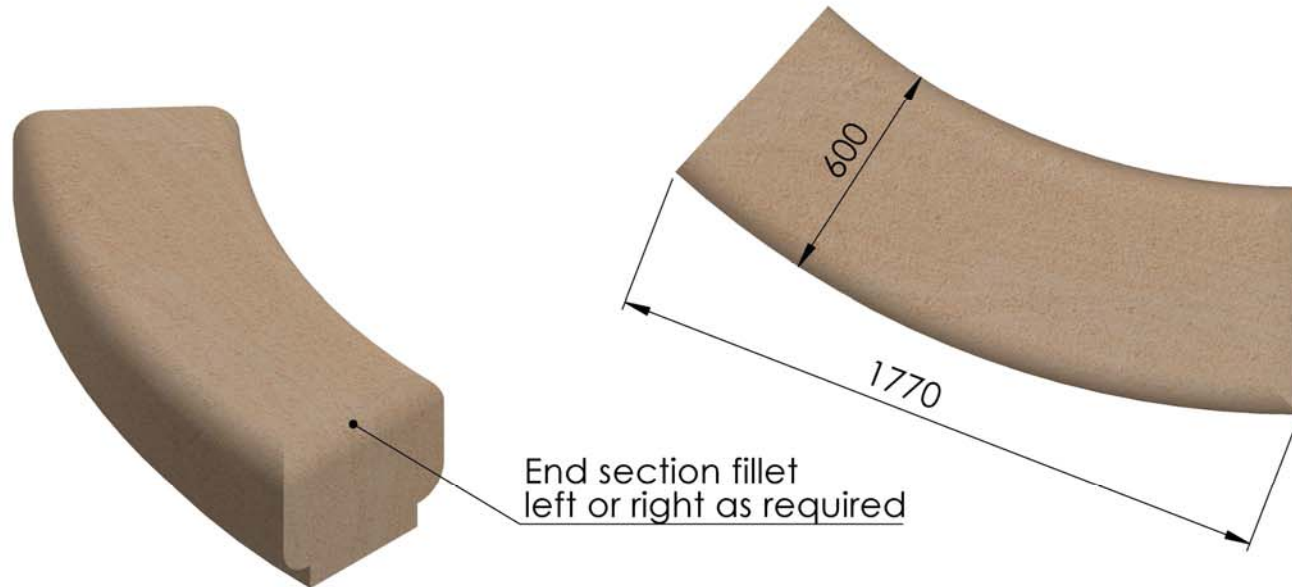
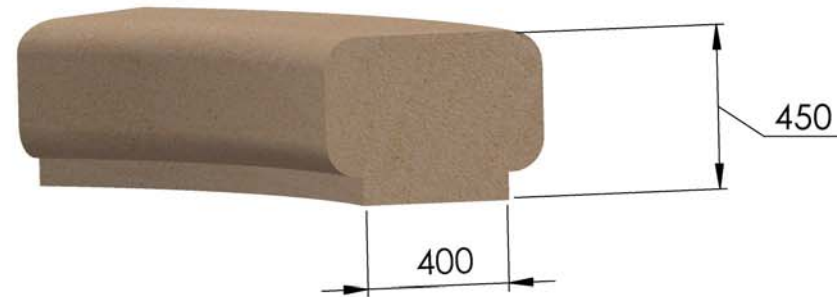

All dimensions are in millimetres. For non listed sizes please contact InGranite Recon LTD.

All vertical faces typically have a 4mm taper per 100mm of height.

The information contained in this drawing was correct at the time of going to print. Profiles, sizes and weights are given as indication only.



# InGranite Recon Ltd.

Reconstituted Stone | Modern Material | Classic Style

UK info@ingranite.co.uk

www.ingranite.co.uk

0808 2349118

RoI info@ingranite.ie

www.ingranite.ie

057 9331462

## Technical specification sheet

Title: Star bench A

Date: 02/03/2017

Ref: SB01

Scale: 1:25

Drawn by: InGranite

Approximate weight: 1014kgs

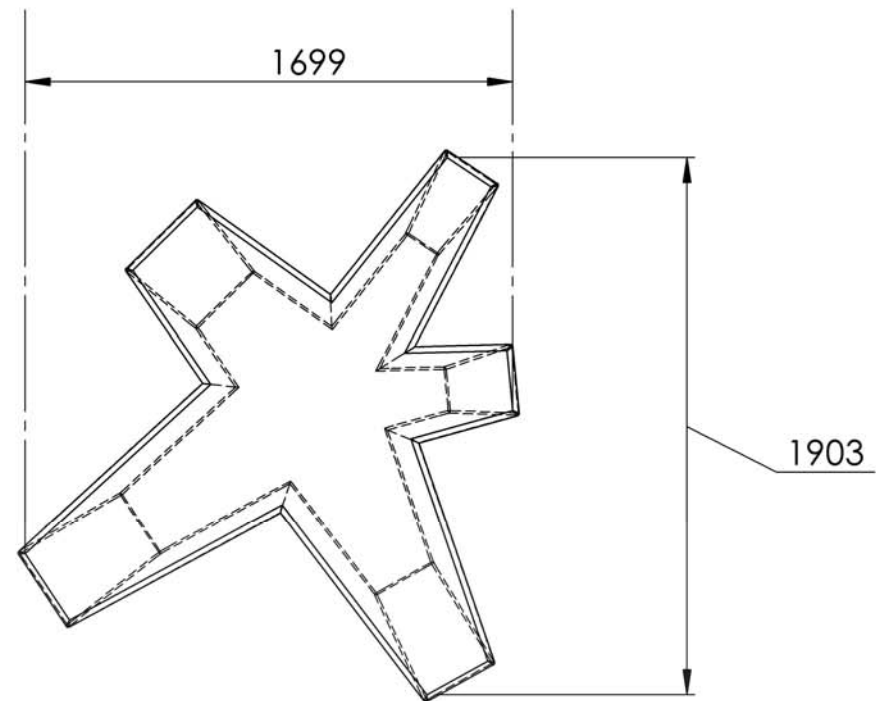
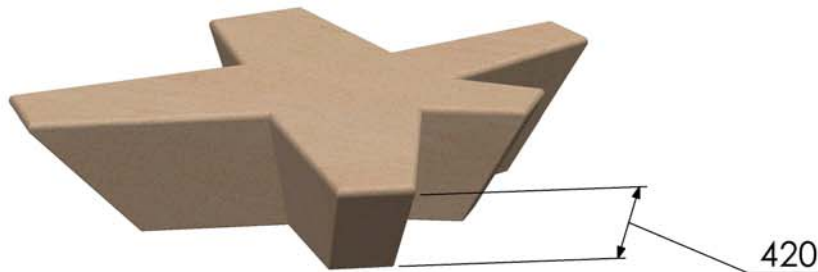
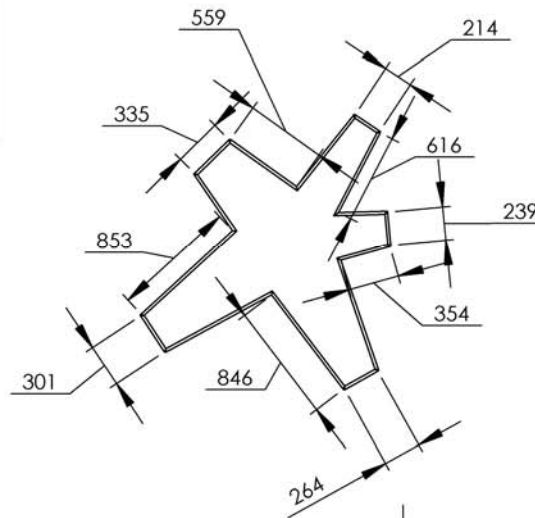

All dimensions are in millimetres. For non listed sizes please contact InGranite Recon LTD.

All vertical faces typically have a 4mm taper per 100mm of height.

The information contained in this drawing was correct at the time of going to print. Profiles, sizes and weights are given as indication only.





# InGranite Recon Ltd.

Reconstituted Stone | Modern Material | Classic Style

UK info@ingranite.co.uk

www.ingranite.co.uk

0808 2349118

RoI info@ingranite.ie

www.ingranite.ie

057 9331462

## Technical specification sheet

Title: Star bench B

Date: 02/03/2017

Ref: SB02

Scale: 1:25

Drawn by: InGranite

Approximate weight: 1745kgs

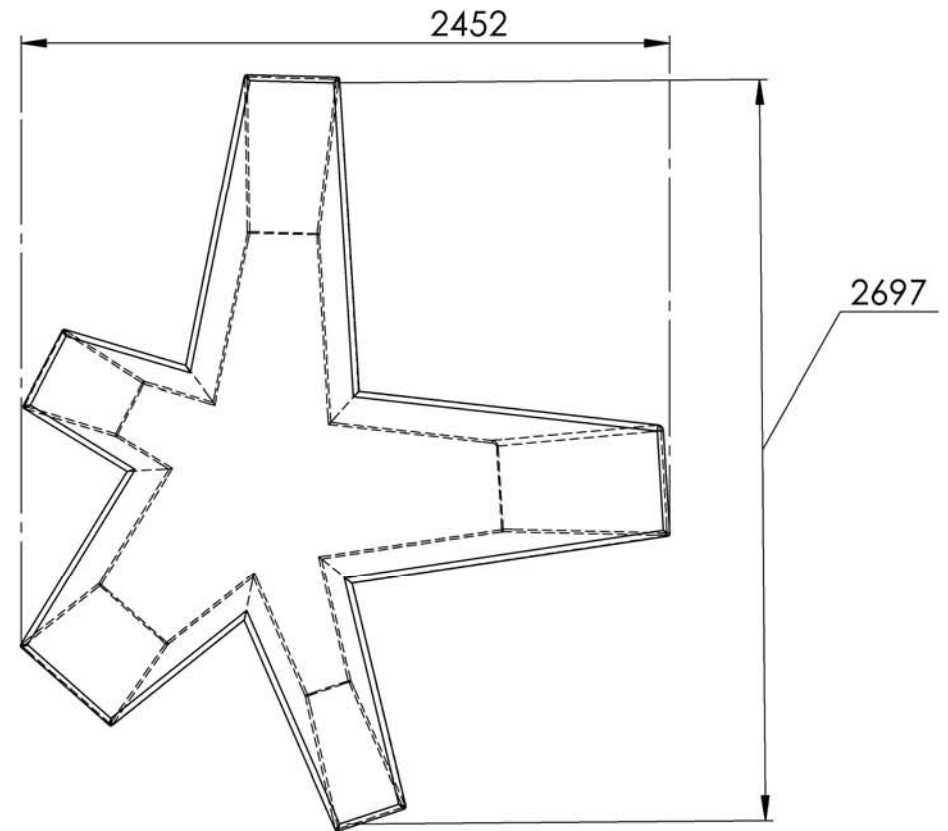
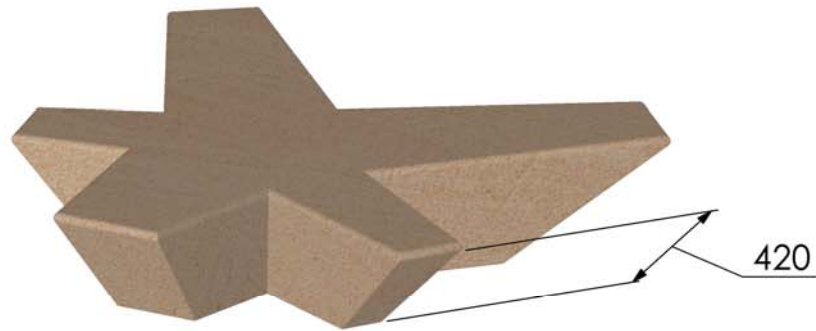
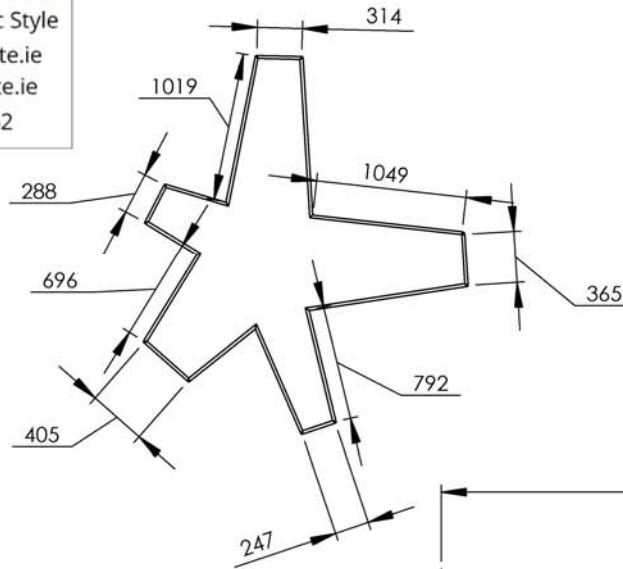

All dimensions are in millimetres. For non listed sizes please contact InGranite Recon LTD.

All vertical faces typically have a 4mm taper per 100mm of height.

The information contained in this drawing was correct at the time of going to print. Profiles, sizes and weights are given as indication only.



# InGranite Recon Ltd.

Reconstituted Stone | Modern Material | Classic Style

UK info@ingranite.co.uk

www.ingranite.co.uk

0808 2349118

RoI info@ingranite.ie

www.ingranite.ie

057 9331462

## Technical specification sheet

Title: Variable height seat

Date: 07/04/2017

Ref: VH 1500

Scale: 1:20

Drawn by: InGranite

Approximate weight:

198kgs/meter

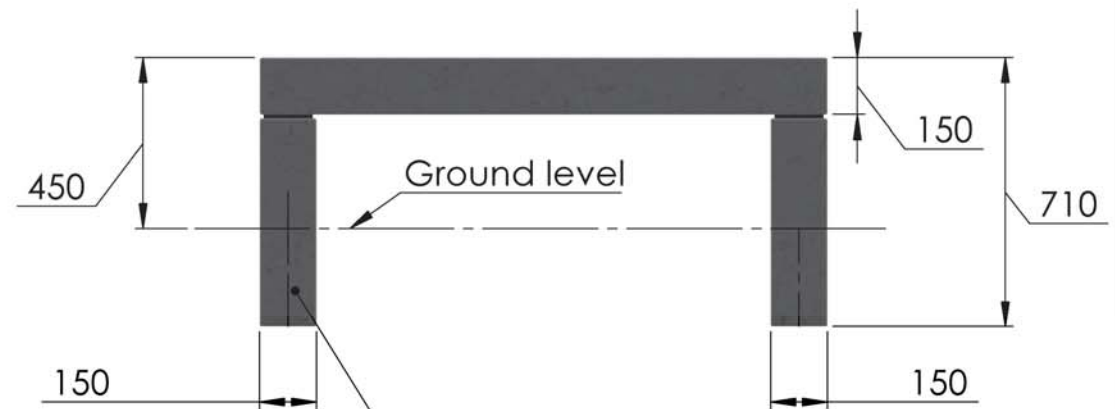
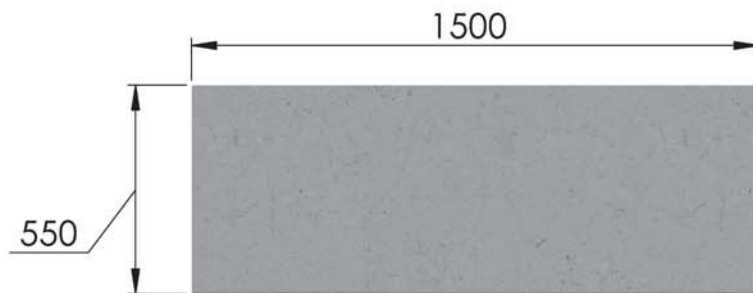

All dimensions are in millimetres. For non listed sizes please contact InGranite Recon LTD.

All vertical faces typically have a 4mm taper per 100mm of height.

The information contained in this drawing was correct at the time of going to print. Profiles, sizes and weights are given as indication only.



# InGranite Recon Ltd.

Reconstituted Stone | Modern Material | Classic Style

UK info@ingranite.co.uk

www.ingranite.co.uk

0808 2349118

RoI info@ingranite.ie

www.ingranite.ie

057 9331462

## Technical specification sheet

Title: Circular planter

Date: 13/04/2017

Ref: PL 2

Scale: 1:10

Drawn by: InGranite

Approximate weight: 90kgs

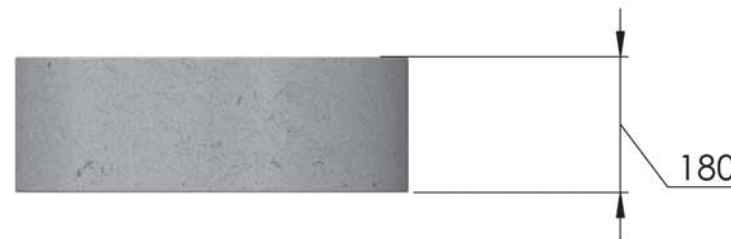
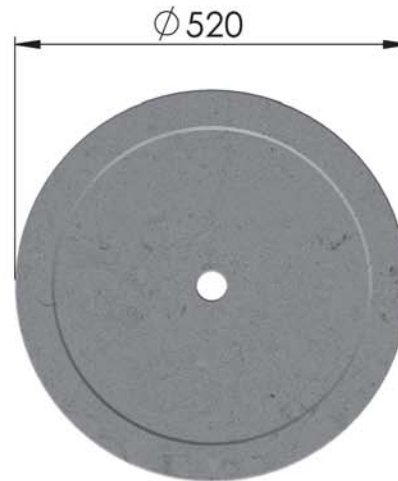

All dimensions are in millimetres. For non listed sizes please contact InGranite Recon LTD.

All vertical faces typically have a 4mm taper per 100mm of height.

The information contained in this drawing was correct at the time of going to print. Profiles, sizes and weights are given as indication only.



# InGranite Recon Ltd.

Reconstituted Stone | Modern Material | Classic Style

UK info@ingranite.co.uk

www.ingranite.co.uk

0808 2349118

RoI info@ingranite.ie

www.ingranite.ie

057 9331462

## Technical specification sheet

Title: Font style planter

Date: 13/04/2017

Ref: PL 5

Scale: 1:20

Drawn by: InGranite

Approximate weight: 650kgs

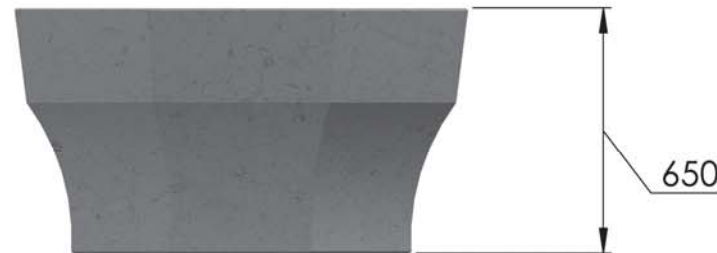
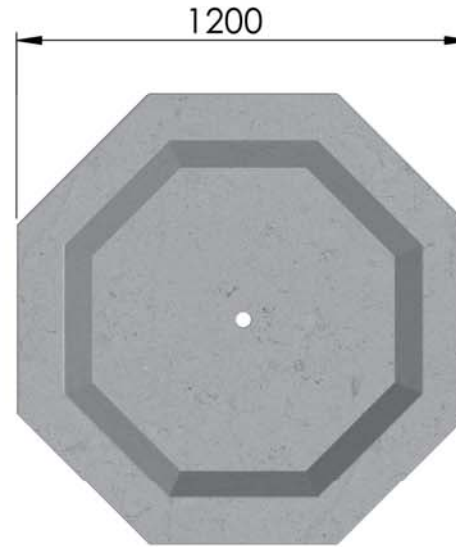

All dimensions are in millimetres. For non listed sizes please contact InGranite Recon LTD.

All vertical faces typically have a 4mm taper per 100mm of height.

The information contained in this drawing was correct at the time of going to print. Profiles, sizes and weights are given as indication only.



# InGranite Recon Ltd.

Reconstituted Stone | Modern Material | Classic Style

UK info@ingranite.co.uk

www.ingranite.co.uk

0808 2349118

RoI info@ingranite.ie

www.ingranite.ie

057 9331462

## Technical specification sheet

Title: Octagonal planter A

Date: 13/04/2017

Ref: PL 3

Scale: 1:10

Drawn by: InGranite

Approximate weight:

200kgs

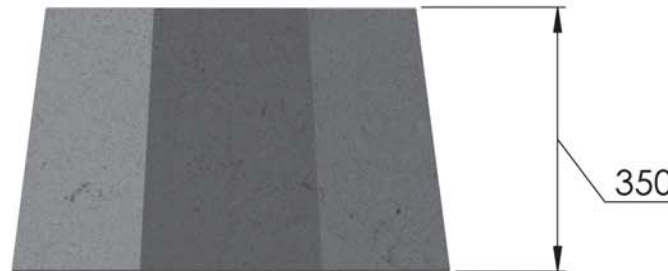
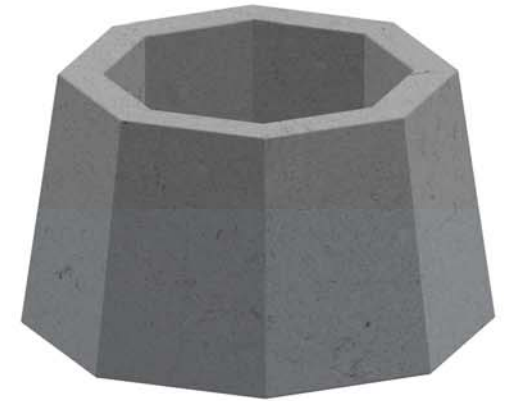
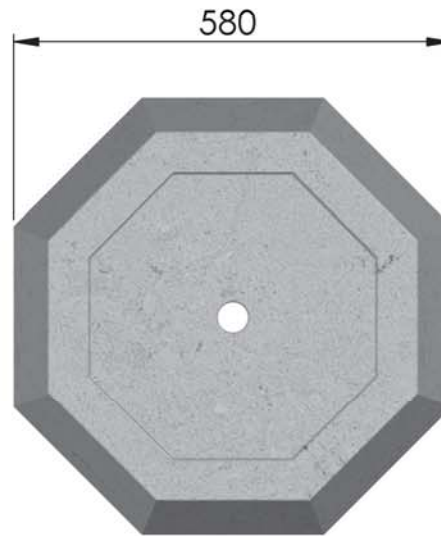

All dimensions are in millimetres. For non listed sizes please contact InGranite Recon LTD.

All vertical faces typically have a 4mm taper per 100mm of height.

The information contained in this drawing was correct at the time of going to print. Profiles, sizes and weights are given as indication only.





# InGranite Recon Ltd.

Reconstituted Stone | Modern Material | Classic Style

UK info@ingranite.co.uk

www.ingranite.co.uk

0808 2349118

RoI info@ingranite.ie

www.ingranite.ie

057 9331462

## Technical specification sheet

Title: Octagonal planter B

Date: 13/04/2017

Ref: PL 4

Scale: 1:20

Drawn by: InGranite

Approximate weight: 450kgs

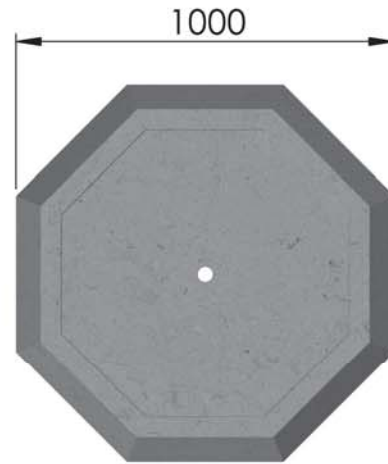
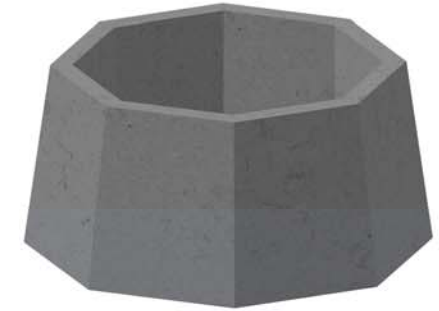

All dimensions are in millimetres. For non listed sizes please contact InGranite Recon LTD.

All vertical faces typically have a 4mm taper per 100mm of height.

The information contained in this drawing was correct at the time of going to print. Profiles, sizes and weights are given as indication only.



# InGranite Recon Ltd.

Reconstituted Stone | Modern Material | Classic Style

UK info@ingranite.co.uk

www.ingranite.co.uk

0808 2349118

RoI info@ingranite.ie

www.ingranite.ie

057 9331462

## Technical specification sheet

Title: Rock face planter

Date: 13/04/2017

Ref: PL 1

Scale: 1:10

Drawn by: InGranite

Approximate weight:

90kgs

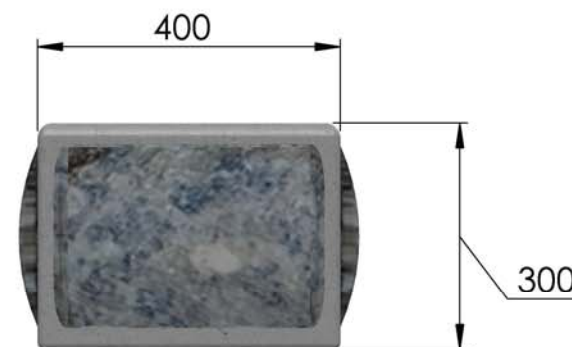

All dimensions are in millimetres. For non listed sizes please contact InGranite Recon LTD.

All vertical faces typically have a 4mm taper per 100mm of height.

The information contained in this drawing was correct at the time of going to print. Profiles, sizes and weights are given as indication only.



# InGranite Recon Ltd.

Reconstituted Stone | Modern Material | Classic Style

UK info@ingranite.co.uk

RoI info@ingranite.ie

www.ingranite.co.uk

www.ingranite.ie

0808 2349118

057 9331462

## Technical specification sheet

Title:	Bollard 1		
Date:	28/03/2017	Ref:	BD 1
Scale:	1:15	Drawn by:	InGranite
Approximate weight:	385kgs		

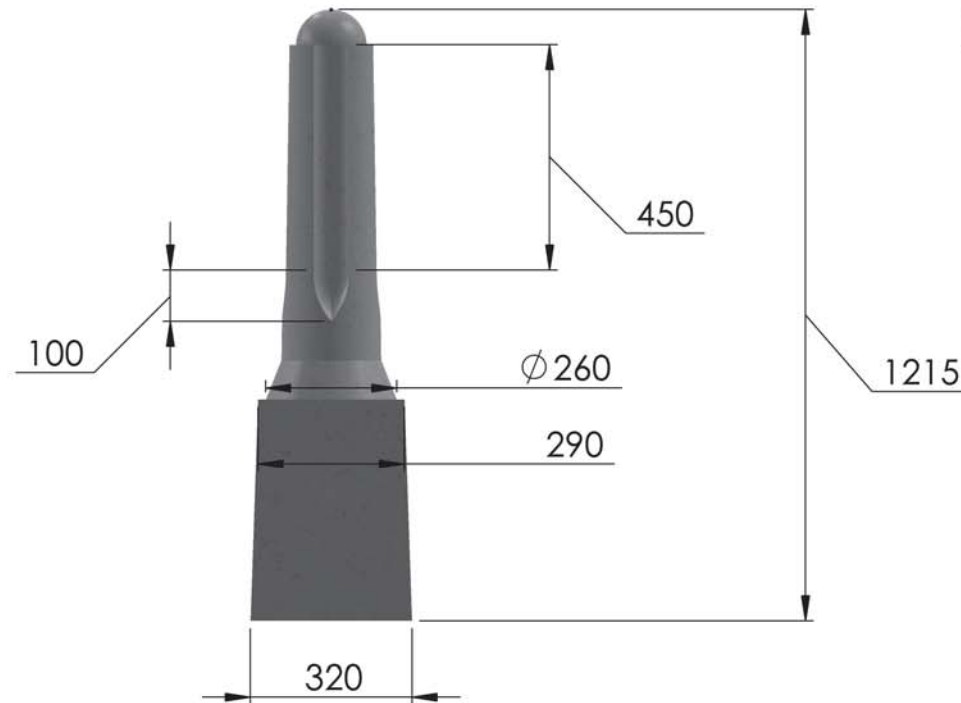
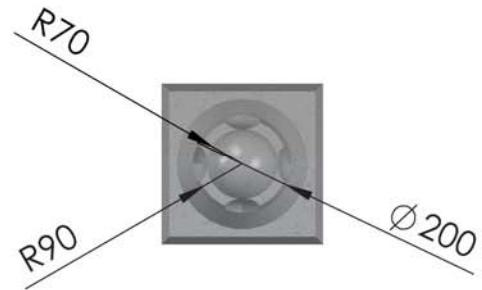

All dimensions are in millimetres. For non listed sizes please contact InGranite Recon LTD.

All vertical faces typically have a 4mm taper per 100mm of height.

The information contained in this drawing was correct at the time of going to print. Profiles, sizes and weights are given as indication only.



# InGranite Recon Ltd.

Reconstituted Stone | Modern Material | Classic Style

UK info@ingranite.co.uk

RoI info@ingranite.ie

www.ingranite.co.uk

www.ingranite.ie

0808 2349118

057 9331462

## Technical specification sheet

Title: **Bollard 2**

Date: 28/03/2017

Ref: BD 2

Scale: 1:15

Drawn by: InGranite

Approximate weight:

216kgs

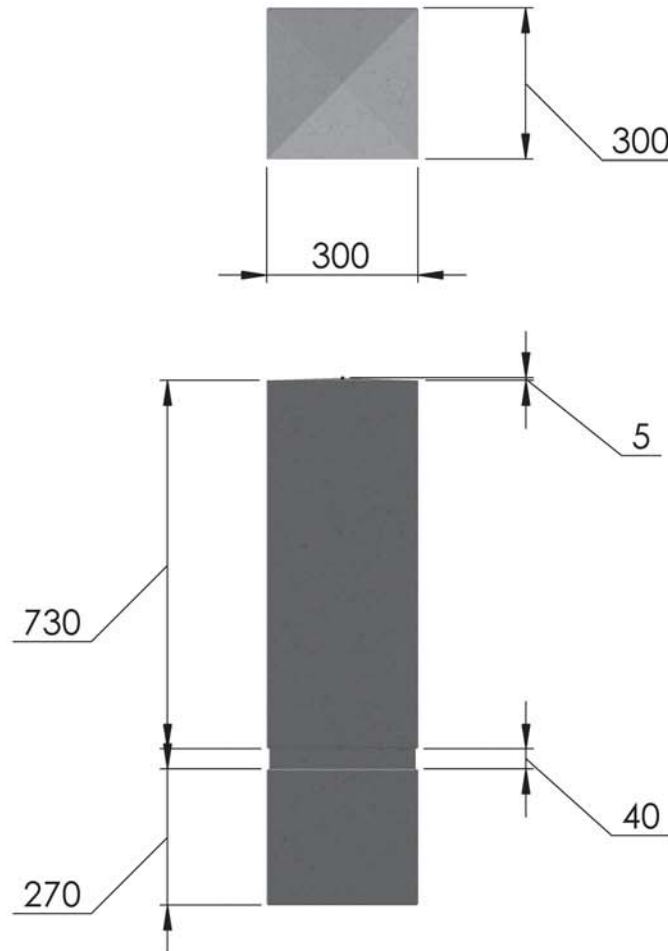

All dimensions are in millimetres. For non listed sizes please contact InGranite Recon LTD.

All vertical faces typically have a 4mm taper per 100mm of height.

The information contained in this drawing was correct at the time of going to print. Profiles, sizes and weights are given as indication only.



# InGranite Recon Ltd.

Reconstituted Stone | Modern Material | Classic Style

UK info@ingranite.co.uk

RoI info@ingranite.ie

www.ingranite.co.uk

www.ingranite.ie

0808 2349118

057 9331462

## Technical specification sheet

Title: **Bollard 3**

Date: 28/03/2017

Ref: BD 3

Scale: 1:15

Drawn by: InGranite

Approximate weight:

298kgs

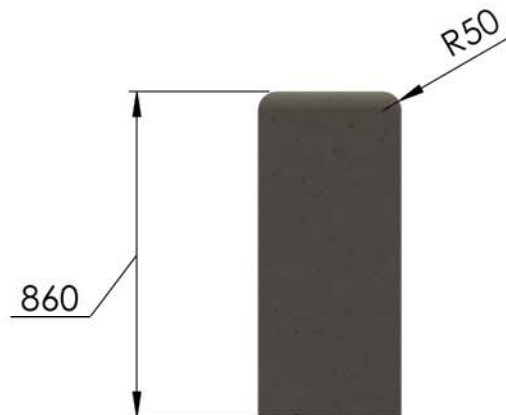
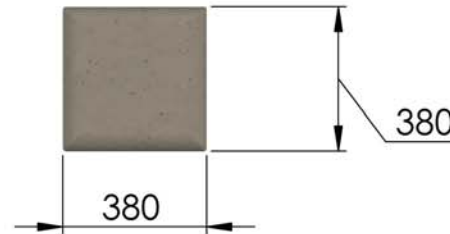

All dimensions are in millimetres. For non listed sizes please contact InGranite Recon LTD.

All vertical faces typically have a 4mm taper per 100mm of height.

The information contained in this drawing was correct at the time of going to print. Profiles, sizes and weights are given as indication only.





# InGranite Recon Ltd.

Reconstituted Stone | Modern Material | Classic Style

UK info@ingranite.co.uk

RoI info@ingranite.ie

www.ingranite.co.uk

www.ingranite.ie

0808 2349118

057 9331462

## Technical specification sheet

Title: <b>Bollard 4</b>	
Date: 28/03/2017	Ref: BD 4
Scale: 1:15	Drawn by: InGranite
Approximate weight:	145kgs

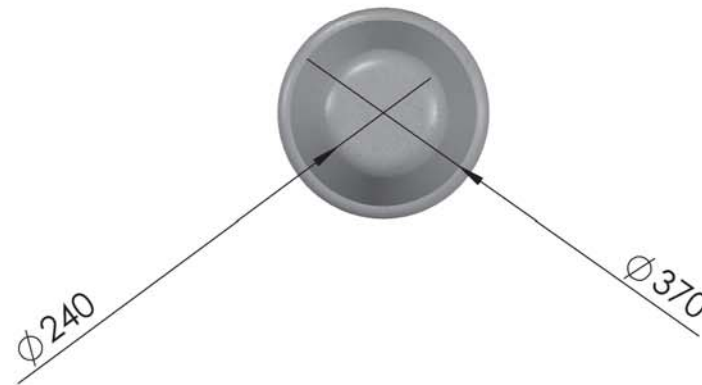

All dimensions are in millimetres. For non listed sizes please contact InGranite Recon LTD.

All vertical faces typically have a 4mm taper per 100mm of height.

The information contained in this drawing was correct at the time of going to print. Profiles, sizes and weights are given as indication only.



# InGranite Recon Ltd.

Reconstituted Stone | Modern Material | Classic Style

UK info@ingranite.co.uk

RoI info@ingranite.ie

www.ingranite.co.uk

www.ingranite.ie

0808 2349118

057 9331462

## Technical specification sheet

Title: Single ring bollard

Date: 11/04/2017

Ref: BD 5

Scale: 1:10

Drawn by: InGranite

Approximate weight:

141kgs

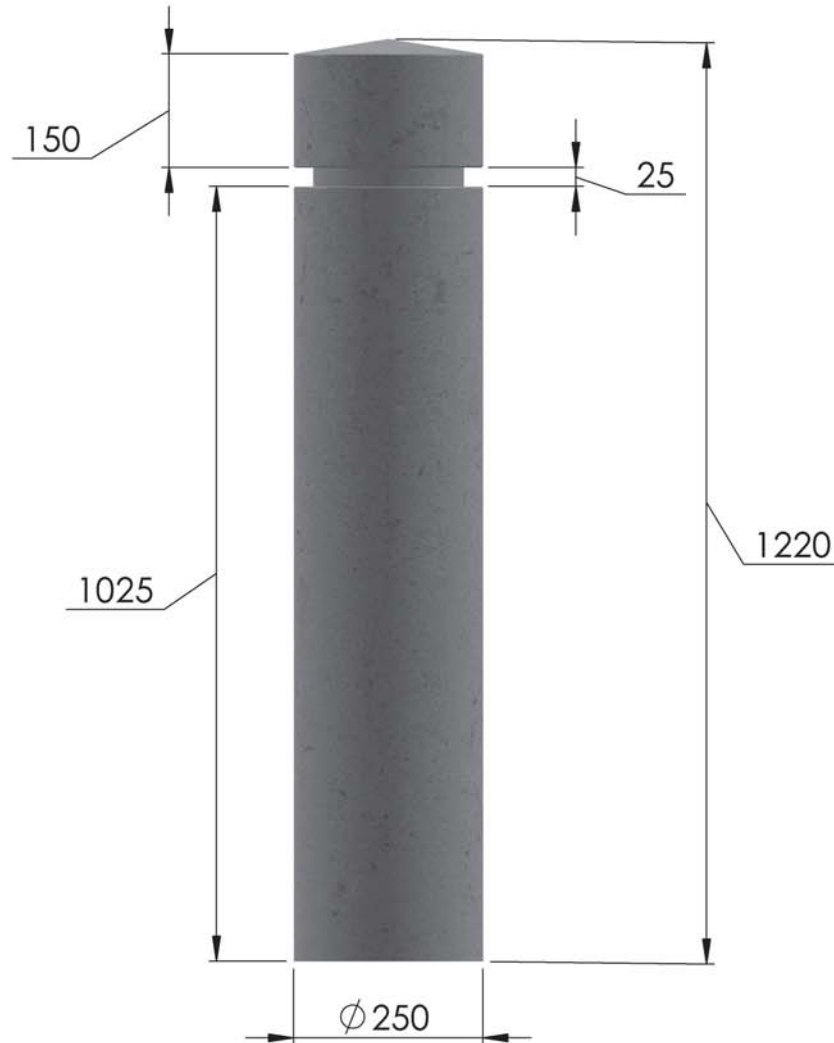

All dimensions are in millimetres. For non listed sizes please contact InGranite Recon LTD.

All vertical faces typically have a 4mm taper per 100mm of height.

The information contained in this drawing was correct at the time of going to print. Profiles, sizes and weights are given as indication only.



# InGranite Recon Ltd.

Reconstituted Stone | Modern Material | Classic Style

UK info@ingranite.co.uk

www.ingranite.co.uk

0808 2349118

RoI info@ingranite.ie

www.ingranite.ie

057 9331462

## Technical specification sheet

Title: Double ring bollard

Date: 11/04/2017

Ref: BD 6

Scale: 1:10

Drawn by: InGranite

Approximate weight: 146kgs

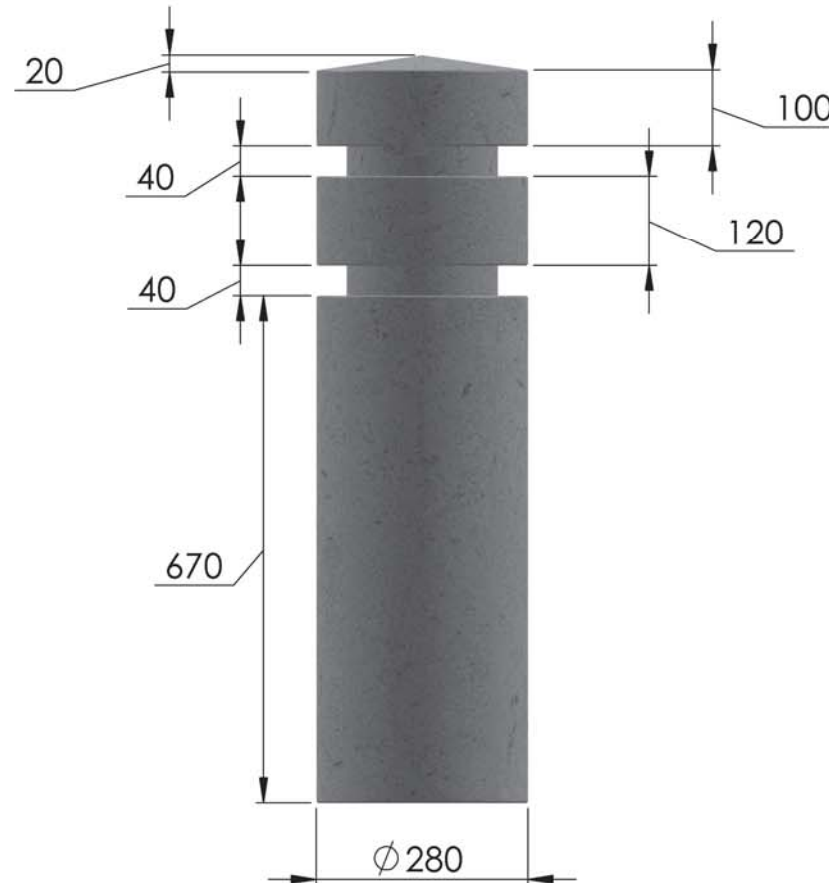

All dimensions are in millimetres. For non listed sizes please contact InGranite Recon LTD.

All vertical faces typically have a 4mm taper per 100mm of height.

The information contained in this drawing was correct at the time of going to print. Profiles, sizes and weights are given as indication only.



# InGranite Recon Ltd.

Reconstituted Stone | Modern Material | Classic Style

UK info@ingranite.co.uk

www.ingranite.co.uk

0808 2349118

RoI info@ingranite.ie

www.ingranite.ie

057 9331462

## Technical specification sheet

Title: Conical bollard 1240

Date: 11/04/2017

Ref: BD 7

Scale: 1:10

Drawn by: InGranite

Approximate weight: 100kgs

1240

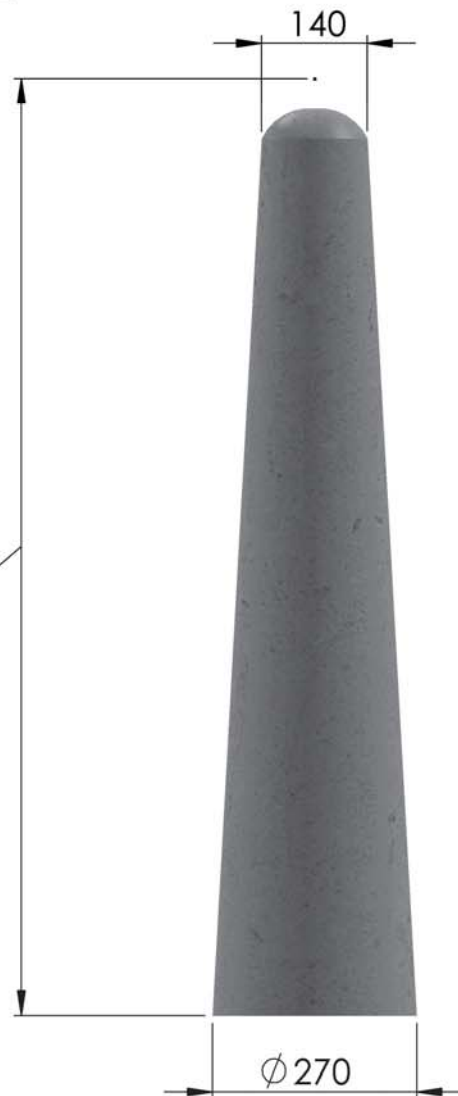

All dimensions are in millimetres. For non listed sizes please contact InGranite Recon LTD.

All vertical faces typically have a 4mm taper per 100mm of height.

The information contained in this drawing was correct at the time of going to print. Profiles, sizes and weights are given as indication only.



# InGranite Recon Ltd.

Reconstituted Stone | Modern Material | Classic Style

UK info@ingranite.co.uk

www.ingranite.co.uk

0808 2349118

RoI info@ingranite.ie

www.ingranite.ie

057 9331462

## Technical specification sheet

Title: Pyramidal bollard

Date: 11/04/2017

Ref: BD 8

Scale: 1:10

Drawn by: InGranite

Approximate weight:

Not available

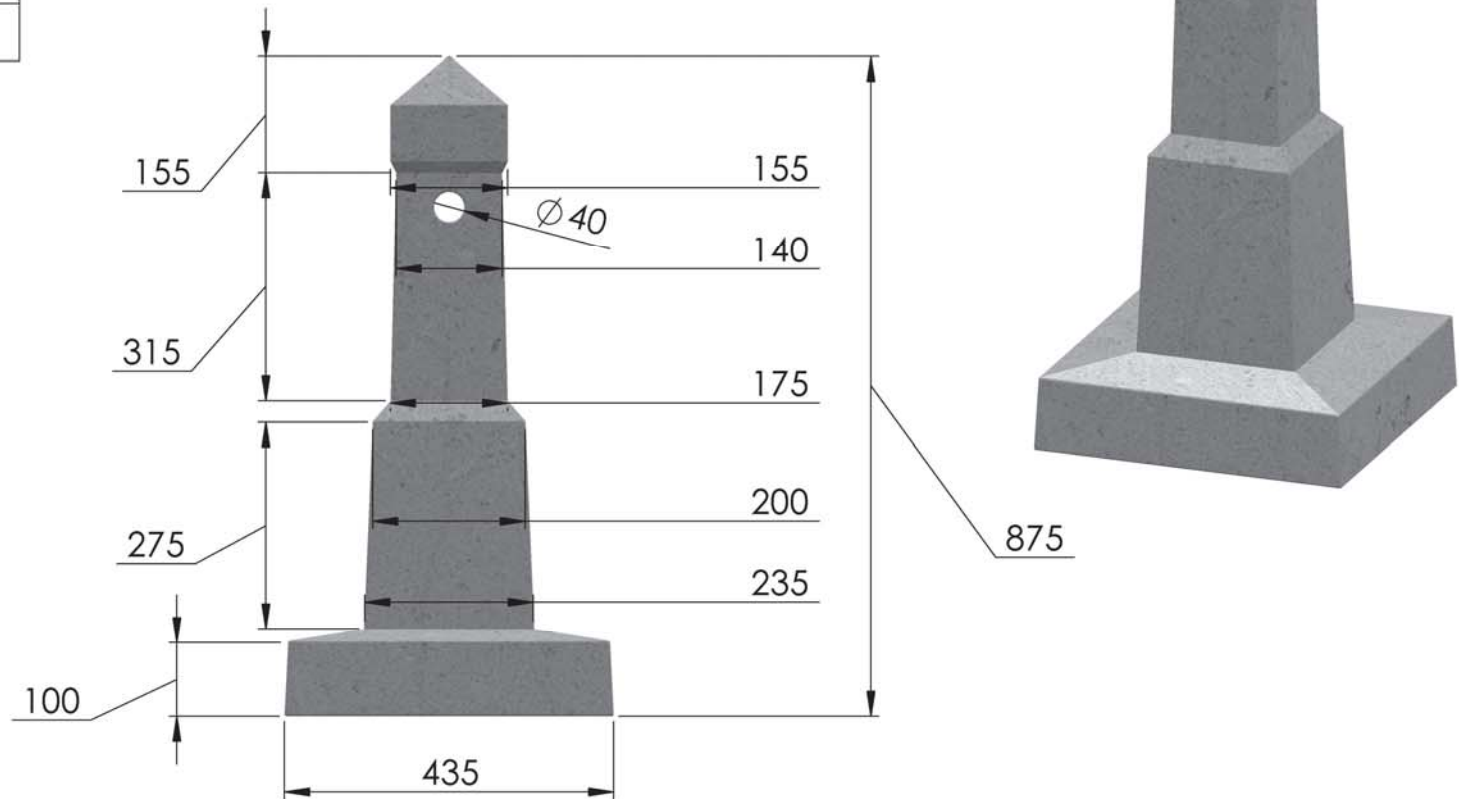

All dimensions are in millimetres. For non listed sizes please contact InGranite Recon LTD.

All vertical faces typically have a 4mm taper per 100mm of height.

The information contained in this drawing was correct at the time of going to print. Profiles, sizes and weights are given as indication only.